



XS 250

PR-2226

This product manual contains important information about the safe installation and use of this projector. Please read and follow these instructions carefully and keep this manual in a safe place for future reference.

PR LIGHTING LTD.
<http://www.pr-lighting.com>

INDEX

SAFE USAGE OF THE PROJECTOR	3
INSTALLING THE PROJECTOR	4
FITTING THE LAMP	4
POWER SUPPLY – MAINS	5
CONTROL CONNECTIONS	5
DMX TERMINATOR	6
SETUP OPTIONS-PROJECTOR CONFIGURATION	6
TO SET THE DMX START ADDRESS	6
MASTER/SLAVE MODE	7
STAND-ALONE MODE	7
OPERATION MENU	8
ERROR MESSAGES	11
REPLACING GOBOS	11
DMX PROTOCOL	12
LED INDICATION	14
MAINTENANCE	14
LUBRICATION	14
KEEPING THE PROJECTOR CLEAN	14
TROUBLESHOOTING	15
TECHNICAL DATA	16
ELECTRICAL DIAGRAM	19
COMPONENT ORDER CODES	20

Please note that as part of our ongoing commitment to continuous product development, specifications are subject to change without notice. Whilst every care is taken in the preparation of this manual we reserve the right to change specifications in the course of product improvement. The publishers cannot be held responsible for the accuracy of the information herein, or any consequence arising from them.

Every unit is tested completely and packed properly by the manufacturer. Please make sure the packing and / or the unit are in good condition before installation and use. Should there be any damage caused by transportation, consult your dealer and do not use the unit. Any damage caused by improper use will not be assumed by the manufacturer and / or dealer.

ACCESSORIES

These items are packed together with the projector:

Name	Quantity	Unit	Remark
Clamps	2	Pcs	
Screws for clamp	4	Pcs	
XLR cable	1	Pc	5-pin plug
Safety cord	1	Pc	
Spare gobos	4	Pcs	
This manual	1	Pc	

SAFE USAGE OF THE PROJECTOR

When unpacking and before disposing of the carton check there is no transportation damage before using the projector. Should there be any damage caused by transportation, consult your dealer and do not use the apparatus.

The projector is for indoor use only, IP20. Use only in dry locations. Keep this device away from rain and moisture, excessive heat, humidity and dust. Do not allow contact with water or any other liquids.

The projector is not designed or intended to be mounted directly on to inflammable surfaces.



The projector is only intended for installation, operation and maintenance by qualified personnel.

The projector must be installed in a location with adequate ventilation, at least 50cm from adjacent wall surfaces. Be sure that no ventilation slots are blocked.

Do not project the beam onto inflammable surfaces, minimum distance is 5m. \sphericalangle 5m E

Avoid direct exposure to the light from the lamp. The light is harmful to the eye.

Do not attempt to dismantle and/or modify the projector in any way.

Electrical connection must only be carried out by qualified personnel.

Before installation, ensure that the voltage and frequency of power supply match the power requirements of the projector.

It is essential that each projector is correctly earthed and that electrical installation conforms to all relevant standards.

Do not connect this device to any other types of dimmer apparatus.

Make sure that the power-cord is never crimped or damaged by sharp edges. Never let the power-cord come into contact with other cables. Only handle the power-cord by the plug. Never pull out the plug by tugging the power-cord.

Keep the lamp clean. Do not touch the lamp glass with bare hand.

The projector should always be installed with a secondary safety fixing. A safety cord is supplied for this; it should be attached as shown in "installing the projector" section.

The lamp used in this projector is a discharge lamp. After switching off don't attempt to restart the projector until lamp has cooled, this will require approx 15 minutes. Switching the lamp on and off at short intervals will reduce the life of both the lamp and the projector. But occasional breaks will prolong the life of the lamp and projector.

Never run the projector without a lamp.

The lamp shall be changed if it has become damaged or thermally deformed.

Shields and lens shall be changed if they have become visibly damaged to such an extent than their effectiveness is impaired, for example by cracks or deep scratches.

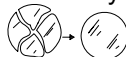

Exterior surface temperatures of the luminaire after 5 minutes operation is 80°C, when steady state is achieved 120°C,

There is no user serviceable parts inside the projector, do not open the housing and never operate the projector with the covers removed.

Always disconnect from the mains, when the device is not in use or before cleaning it or before attempting any maintenance work !

If you have any questions, don't hesitate to consult your dealer or manufacturer.

INSTALL THE PROJECTOR

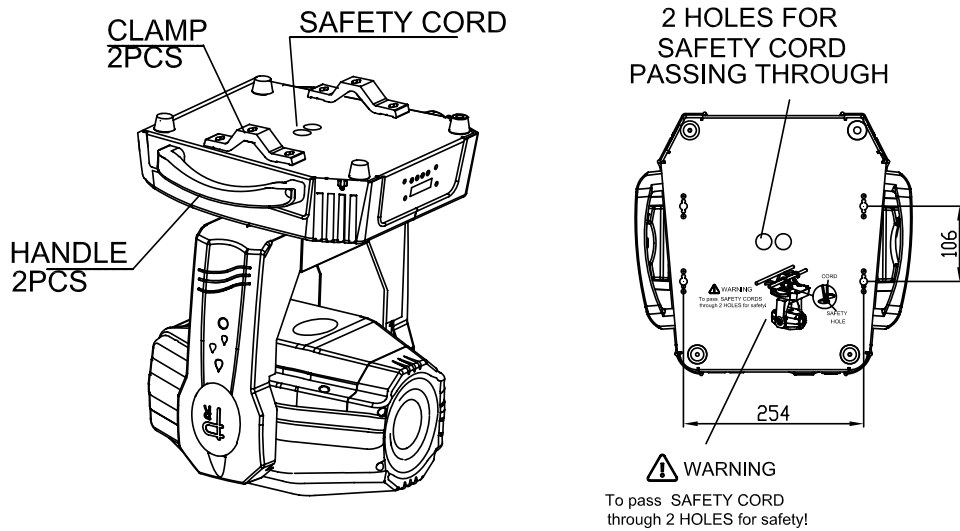

Take 2 clamps and the safety cord out from the package and mount 2 clamps on the underside of fixture with 2 retainers attached to each clamp. Hang the fixture on the structure and fasten the screws attached to each clamp. (See the **WARNING** on the underside of the base as shown above) **To pass SAFETY CORD through 2 HOLES for safety!** Always ensure that the projector is firmly anchored to avoid vibration and slipping whilst functioning. Always ensure that the structure that you are going to mount the projector is secure and is strong enough to support a weight of XS 250.

WARNING:

1. Unlock the PAN and TILT before the 1st application of projector for safety.
2. The projector **MUST** be lifted or carried by the HANDLES instead of clamps.
3. For safety the safety cord should afford 10 times of the unit's weight.

FITTING THE LAMP

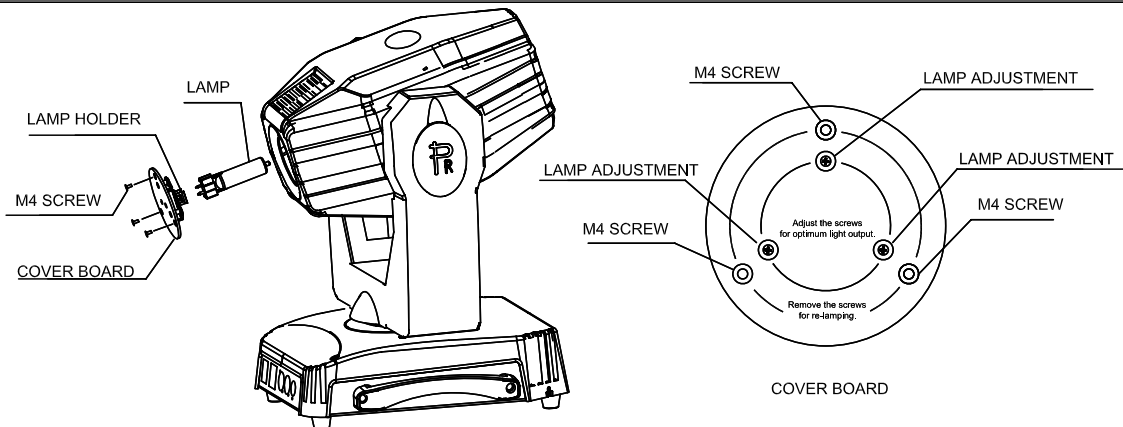

Lock the yoke before fitting/replacing the lamp.

Open the cover board at the rear of the projector by loosening 3 screws, you can see the structure as shown in the figure above.

Gently pull out lamp holder assembly.

Take out the worn-out lamp. Insert the new lamp to the socket. **Note:** don't touch the bulb of the new lamp with bare hand so as not to influence the beam output.

Close the rear cover and fasten 3 screws.

WARNING: The MSD series are high-pressure lamps with external igniters (⚠). Care should always be taken when handling these lamps. Always read the manufacturers "Instructions for use" enclosed with the lamp.

POWER SUPPLY-MAINS

Connect the power cord as follows:

- L (live) =brown
- E (earth) =yellow/green
- N (neutral) =blue

Use the plug provided to connect the mains power to the projector paying attention to the voltage and frequency marked on the panel of the projector. It is recommended that each projector be supplied separately so that they may be individually switched on and off.

IMPORTANT

It is essential that each projector is correctly earthed and the electrical installation conforms to all relevant standards.

CONTROL CONNECTION

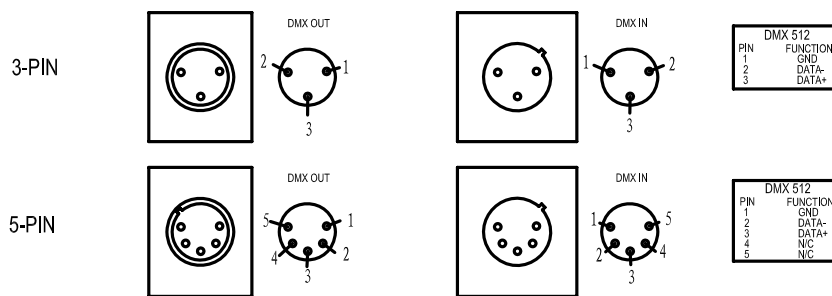

Connection between controller and projector and between one projector and another must be made with a 2 core-screened cable, with each core having at least a 0.5mm diameter. Connection to and from the projector is via cannon 3 pin (which are included with the projector) or 5 pin XLR plugs and sockets. The XLR's are connected as shown in the figure above.

Note: care should be taken to ensure that none of the pins touch the metallic body of the plug or each other. The body of the plug is not connected in any way. The XS 250 accepts digital control signals in protocol DMX512 (1990).

Connect the controller's output to the first fixture's input, and connect the first fixture's output to the second fixture's input and connect the rest fixtures in the same way. Eventually connect the last fixture's output to a DMX terminator as shown in the figure below.

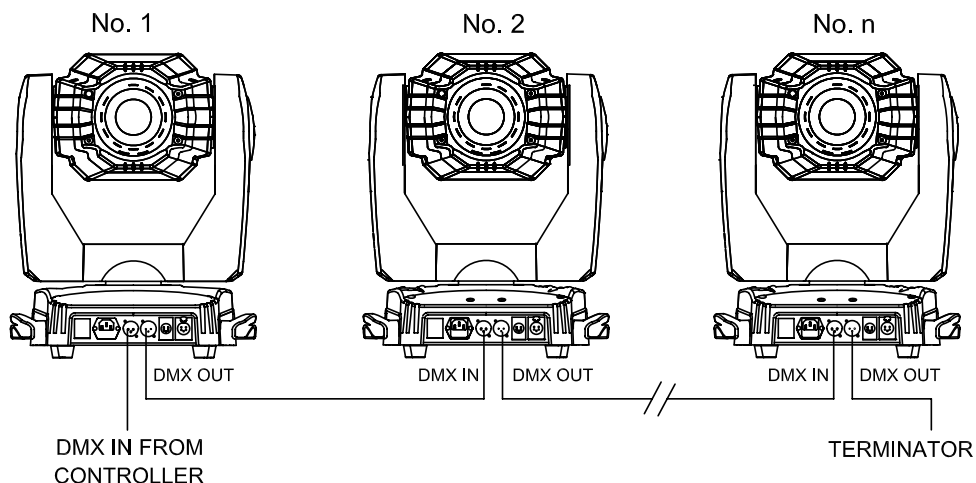

DMX TERMINATOR

In the Controller mode, at the last fixture in the chain, the DMX output has to be connected with a DMX terminator. This prevents electrical noise from disturbing and corrupting the DMX control signals.

The DMX terminator is simply an XLR connector with a 120Ω (ohm) resistor connected across pins 2 and 3, which is then plugged into the output socket on the last projector in the chain. The connections are illustrated below.

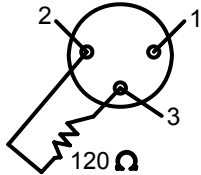

DMX TERMINATOR CONNECTION

Connect a 120Ω(OHM) resistor across pins 2 and 3 in an XLR plug and insert into the DMX out socket on the last unit in the chain.

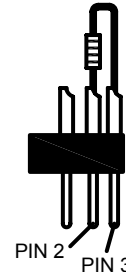

SETUP OPTIONS-PROJECTOR CONFIGURATION

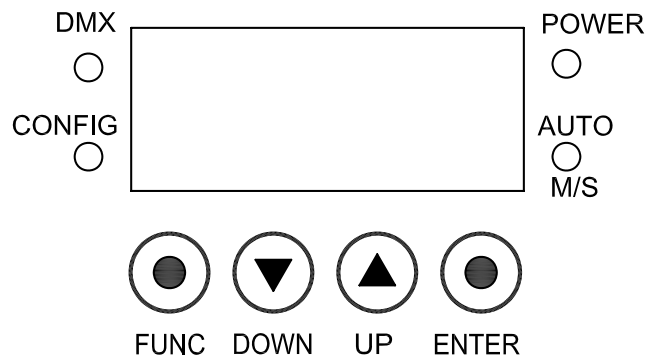

Projector configuration can be set conveniently via pressbutton switch and LED display. Turn the projector on and the LED display will show DMX address you set and save last time and it can be reset and saved again as you please.

Launch the projector. Press button **ENTER** more than 5 seconds to unlock panel.

Press button **UP** or **DOWN** if you want to browse through the various Setup Options. There are 10 option codes from **Addr** to **Edit**, and each code has a specific function.

Press button **ENTER** to save your settings or enter the next menu.

Press button **UP** or **DOWN** to shift.

Press button **FUNC**, it will return to the upper menu one by one. If you stay for minutes defaulted will show display status automatically.

TO SET THE DMX START ADDRESS

Each XS 250 must be given a DMX start address so that the correct projector responds to the correct control signals. This DMX start address is the channel number from which the projector starts to "listen" to the digital control information being sent out from the controller. The XS 250 has 3 DMX modes. There are standard mode, extended mode and short mode. For example standard mode has 16 channels, so set the No. 1 projector's address 001, No. 2 projector's address 017, No. 3 projector's address 033, No. 4 projector's address 049, and so on.

Launch the projector. Press button **ENTER** or coder knob more than 5 seconds to unlock panel.

Press button **FUNC** to display **Addr**.

Press button **UP** and **DOWN**, you can set the address;

Press button **ENTER** to confirm; In the same time. The GREEN LED will flash one time. It means the setting has

been enabled.

Press button **FUNC**, it will return to the upper menu one by one.

STAND-ALONE MODE

Operate the projector without connecting a controller, enable the master mode in the operation panel, the projector will run in Stand-Alone mode automatically.

MASTER/SLAVE MODE

Without using a controller, many projectors can run synchronously in the Master/Slave mode by linking them with each other. Select one projector as the master with setting options master mode enabled but slaves. Regard the other projectors as the slaves with setting options slave mode enabled and all DMX start address "001".

Connect the controller's output to the first fixture's input, and connect the first fixture's output to the second fixture's input and connect the rest fixtures in the same way. Eventually connect the last fixture's output to a DMX terminator as shown in the figure below.

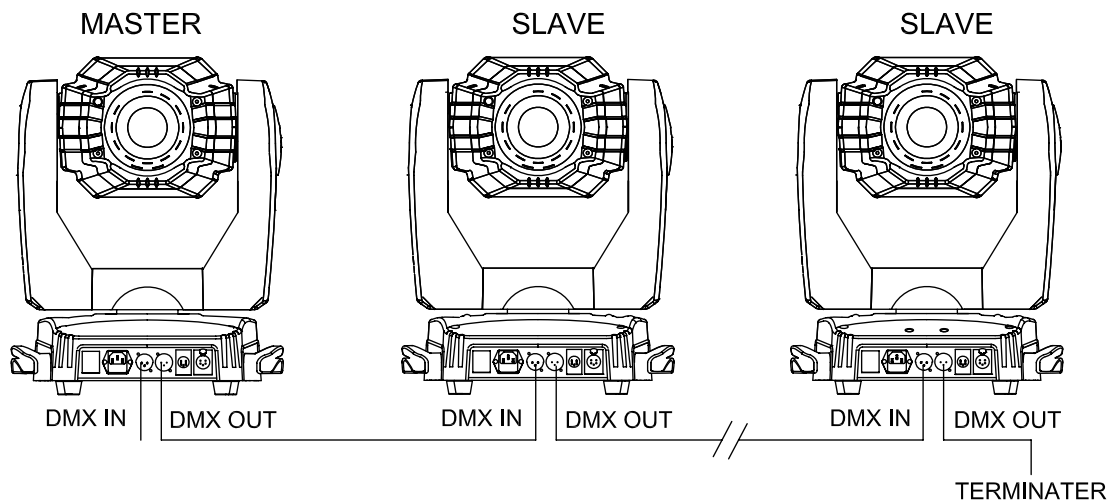

OPERATION MENU

1st LEVEL	2nd LEVEL	3rd LEVEL	4th LEVEL	5th LEVEL	6th LEVEL
AddR	DMX Address 001—501 in Short Mode 001—497 in Standard Mode 001—495 in Extended Mode				
RST	RST?				
CNFG	dMX (Defaults: STd)	STd			
		EXT			
		SHRT			
	LdMX (Defaults: NORM)	NORM			
		HOLD			
	LAMP (Defaults: CTRL)	CTRL			
ON					
dMX					
OPTN	COLR (Defaults: STEP)	STEP			
		LIN			
	GObo (Defaults: STEP)	STEP			
		LIN			
	PIN (Defaults: OFF)	OFF			
		ON			
	TIN (Defaults: OFF)	OFF			
		ON			
	PTS (Defaults: OFF)	OFF			
		ON			
	dIN (Defaults: OFF)	OFF			
		ON			
	IN (Defaults: OFF)	OFF			
		ON			
	ZIN (Defaults: OFF)	OFF			
		ON			
	dFLT (Defaults: OFF)	OFF			
		ON			
dISP	dMD (Defaults: ON)	ON			
		OFF			
		dIM			
	dIN (Defaults: OFF)	OFF			
ON					
INFO	LHR	XX	RST?		
	THR	XX			
	TEMP	MSTR	XX°C		
		HEAd	XX °C		
	VER	MSTR	X.XX		
dMXd	XX				

	SNUM (Reserved)				
TEST	SET (Defaults: OFF)	OFF			
		ON			
	SELF (Defaults: OFF)	OFF			
		ON			
LAMP	STRT	Status = XXX Control = X			
	ON				
	OFF				
MOdE (Defaults :dMX)	dMX				
	MSTR	UM 1	TIME		
			MIC		
		UM 2	TIME		
			MIC		
		PM 1	TIME		
			MIC		
	PM 2	TIME			
		MIC			
	PM 3	TIME			
		MIC			
	SLAV	UM 1	TIME		
			MIC		
		UM 2	TIME		
			MIC		
		PM 1	TIME		
			MIC		
	PM 2	TIME			
		MIC			
	PM 3	TIME			
MIC					
	STAT				
EdIT	MEM	UM 1	SN XX (1~28)	SHUT	XXX (0~255)
				dIM	XXX (0~255)
				COLR	XXX (0~255)
				GObo	XXX (0~255)
				RGbo	XXX (0~255)
				GROT	XXX (0~255)
				PRSM	XXX (0~255)
				PROT	XXX (0~255)
				FOCS	XXX (0~255)
				PANH	XXX (0~255)
				PANL	XXX (0~255)
				TLTH	XXX (0~255)
		TLTL	XXX (0~255)		
		MSPd	XXX (000~255)		
		dELY	XXX (0.25s~100min)		
		LINK	XX (1~28)		
		UM 2	SN XX (1~28)	SHUT	XXX (0~255)
				dIM	XXX (0~255)
				COLR	XXX (0~255)

				GObO	XXX (0~255)
				RGbO	XXX (0~255)
				GROT	XXX (0~255)
				PRSM	XXX (0~255)
				PROT	XXX (0~255)
				FOCS	XXX (0~255)
				PANH	XXX (0~255)
				PANL	XXX (0~255)
				TLTH	XXX (0~255)
				TLTL	XXX (0~255)
				MSPd	XXX (000~255)
				dELY	(0.25s~100min)
				LINK	XX (1~28)
		STAT	SHUT	XXX (0~255)	
			dIM	XXX (0~255)	
			COLR	XXX (0~255)	
			GObO	XXX (0~255)	
			RGbO	XXX (0~255)	
			GROT	XXX (0~255)	
			PRSM	XXX (0~255)	
			PROT	XXX (0~255)	
			FOCS	XXX (0~255)	
			PANH	XXX (0~255)	
			PANL	XXX (0~255)	
			TLTH	XXX (0~255)	
			TLTL	XXX (0~255)	
			MSPd	XXX (000~255)	
	INIT	IM1	RM1? (Unlock UP/DOWN/ENTER)	OK	
		IM2	RM2? (Unlock UP/DOWN/ENTER)	OK	
		ISS	RSS? (Unlock UP/DOWN/ENTER)	OK	

ERROR MESSAGES

In the course of launch, XS 250 examines automatically whether there are errors and if there are, it will display information as follows:

Display	Message
SE 1	Zoom (1# motor) error
SE 6	Rotating Gobo wheel (6# motor) error
SE7	Gobo rotation 1 (7# motor 1) error
SE 9	Fixed Gobo wheel (9# motor) error
SE10	Colour wheel (10# motor) error

REPLACING GOBOS

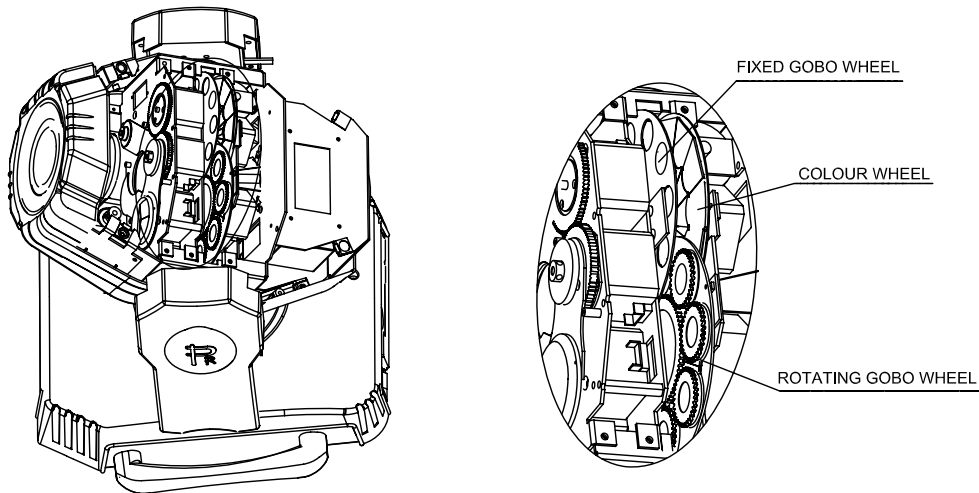

Disconnect the fixture from power. Lock Tilt. Carefully lift off the cover by undoing the 6 screws.

For gobos replacement on the fixed gobo: Remove the gobo and insert the new one into the position by hands.

For gobos replacement on the rotating gobo wheel: Remove the gobo holder with gobo from gobo wheel by hands.

Pull out the spring and drop the old gobo out of the holder.

Insert the new gobo into the holder, and then insert the spring with the narrow end against the gobo.

Push the end of the spring in under lip of the holder.

Pick the spring clip up and put the gobo holder back into the position, if necessary, a small screwdriver will be helped.

Note: If the gobo is a glass one, it should be touched with glabrous, clean and soft tissue or cloth matted between hand and glass instead of with bare hand.

Close the rear cover and fasten 6 screws.

DMX PROTOCOL

Short mode	Standard mode	Extended mode	FUNCTION	DMX	DESCRIPTION
1	1	1	Strobe	000-009	Black
				011-025	Open
				026-225	Strobe speed from slow to fast
				226-255	Open
2	2	2	Dimmer	000-255	Dimming from dark to light (0-100%)
		3	Dimmer Fine	000-255	Dimmer in 16 Bit precision
3	3	4	Colour Wheel	000-020	White
				021-028	Colour 1
				029-037	Colour 2
				038-045	Colour 3
				046-054	Colour 4
				055-062	Colour 5
				063-071	Colour 6
				072-080	Colour 7
				081-088	Colour 8
				089-097	Colour 9
				098-105	Colour 10
				106-114	Colour 11
				115-123	Colour 12
				124-127	white
				128-187	Rainbow rotation speed from slow to fast
				188-195	Stop in current position
196-255	Rainbow reverse rotation speed from slow to fast				
4	4	5	Fixed Gobo Wheel	000-011	Clear
				012-023	Gobo1
				024-034	Gobo 2
				035-046	Gobo 3
				047-057	Gobo 4
				058-069	Gobo 5
				070-080	Gobo 6
				081-092	Gobo 7
				093-103	Gobo
				104-115	Gobo
				116-127	Gobo
				128-150	Rainbow rotation speed from slow to fast
				151-171	Rainbow reverse rotation speed from slow to fast
				172-183	Gobo shake 1 (From slow to fast)
				184-191	Gobo shake 2 (From slow to fast)
				192-199	Gobo shake 3 (From slow to fast)
200-207	Gobo shake 4 (From slow to fast)				
208-215	Gobo shake 5 (From slow to fast)				

				216-223	Gobo shake 6 (From slow to fast)
				224-231	Gobo shake 7 (From slow to fast)
				232-239	Gobo shake 8 (From slow to fast)
				240-247	Gobo shake 9 (From slow to fast)
				248-255	Gobo shake 10 (From slow to fast)
5	5	6	Rotating Gobo Wheel	000-016	white
				017-032	Gobo1
				033-048	Gobo 2
				049-064	Gobo 3
				065-080	Gobo 4
				081-096	Gobo 5
				097-112	Gobo 6
				113-127	Gobo7
				128-150	Rotation speed from slow to fast
				151-171	Reverse rotation speed from slow to fast
				172-183	Gobo shake 1 speed from slow to fast
				184-195	Gobo shake 2 speed from slow to fast
				196-207	Gobo shake 3 speed from slow to fast
				208-219	Gobo shake 4 speed from slow to fast
				220-231	Gobo shake 5 speed from slow to fast
232-243	Gobo shake 6 speed from slow to fast				
244-255	Gobo shake 7 speed from slow to fast				
6	6	7	Gobo rotation	000-159	0~540°index
				160-188	Rotation speed from slow to fast
				189-229	Stop rotating
				230-255	Reverse rotation speed from slow to fast
	7	8	Gobo rotation Fine	000-255	Gobo rotation in 16 Bit precision
7	8	9	Prism / Frost	000-020	Clear
				021-255	Prism
8	9	10	Prism rotation	000-009	Stop in current position
				010-127	Rotation speed from slow to fast
				128-136	Stop in current position
				137-255	Reverse rotation speed from slow to fast
9	10	11	Focus	000-255	Linearly focusing
		12	Focus Fine	000-255	Focus in 16 precision
10	11	13	Pan	000-255	Pan rotation 540°
	12	14	Pan Fine	000-255	Pan rotation in 16 precision
11	13	15	Tilt	000-255	Tilt rotation 270°
	14	16	Tilt Fine	000-255	Tilt rotation in 16 precision
	15	17	Pan & Tilt speed	000-255	Pan&Tilt speed from fast to slow
12	16	18	Control	000-048	Reserved
				049-080	Reset
				081-112	Reserved
				113-144	Lamp off (stop in DMX value for 10 s)
				145-168	Reserved
				169-200	Lamp power reduced to 50%
				201-223	Reserved
				224-255	Lamp on (See remark below)

Remark:

If you intend to turn on/off the lamp via the last channel of the controller, don't attempt to push the channel to value 224-255 immediately after turning it off, or push the slide bar to value 224-255 to wait it cooling. Under these 2 circumstances, the lamp can not be turned on. The right operation is: turn it off—cool down—push the slide bar to turn it on.

LED INDICATION

Green	On	DMX signal OK
	Off	No DMX signal
	Flash	DMX signal error
Yellow	On	Setting the panel
Blue	On	Power
Red/Green	Red	Running slave mode or self test mode
	Green	Running master mode

MAINTENANCE

If the projector's lens becomes damaged or broken it should be replaced. If the lamp becomes damaged or deformed in any way it must be replaced. If the light from the lamp appears dim this would normally indicate that it is reaching the end of its life and it should be changed at once, aged lamps run to the extremity of their life might explode. If the projector does not function, check the fuses on the power socket of the projector, they should only be replaced by fuses of the same specification. Should these be damaged call a qualified technician before replacement. The projector has thermal protection device that will switch off the projector in case of overheating, should either of these operate, check that the fans are not blocked, and if they are dirty clean them before switching on the projector again. Check that the fans are operational, if not call a qualified technician.

Any maintenance work should only be carried out by qualified technicians.

LUBRICATION

To ensure the continuous rotation of the rotating gobos and linear motion of the lens for focusing, it is recommended that the bearings for the rotating gobos and the 2 shafts for the focusing lens holder be lubricated periodically, preferably every two months. Use only high quality, high-temperature resistant grease instead of any type of oil. When lubricating the bearings, a syringe with a fine needle is the easiest way to introduce the grease to the bearings around each gobo.

KEEPING THE PROJECTOR CLEAN

To ensure the reliability of the projector it should be kept clean. It is recommended that the fans should be cleaned every 15 days. The lens and dichroic colour filters should also be regularly cleaned to maintain an optimum light output. **Do NOT use any type of solvent on dichroic colour filters.**

Cleaning frequency depends on the environment in which the fixture operates: damp, smoke or particularly dirty surroundings can cause greater accumulation of dirt on the unit's optics. A soft cloth and typical glass cleaning products should be used in cleaning. It is recommended to clean the external optics at least once every 20 days and clean the internal optics at least once every 30 / 60 days.

Do not use any organic solvent, e.g. alcohol, to clean the reflector mirror, dichroic colour filters or housing of the apparatus.

TROUBLESHOOTING

PROBLEM	ACTION
The projector doesn't switch on	<ul style="list-style-type: none"> ➤ Check the fuse on the power socket. ➤ Replace the lamp.
The lamp comes on but the projector doesn't respond to the controller	<ul style="list-style-type: none"> ➤ Make sure that the projector is correctly configured. ➤ Replace or repair the DMX cable.
The projector only functions intermittently	<ul style="list-style-type: none"> ➤ Make sure the fan is working and not dirty.
Defective projection	<ul style="list-style-type: none"> ➤ Check the lenses are not broken. ➤ Remove dust or grease from the lenses.
The project image appears to have a halo	<ul style="list-style-type: none"> ➤ Make sure the lamp is installed correctly. ➤ Carefully clean the optical group lenses and the projector components.
The beam appears dim	<ul style="list-style-type: none"> ➤ Check the optics is clean. ➤ Replace with a new lamp of the specified type and rating.

TECHNICAL DATA

VOLTAGES:

220V, 50Hz

Options: 100V/120V/200V/220V/230V/240V AC, 50/60Hz

POWER CONSUMPTION:

370W

LAMP:

PHILIPS	MSD 250W/2
Colour Temperature	8500°K
Socket	GY9.5, single ended
Manufacturers Rated Lamp Life	2000 Hours replacement
Or	
OSRAM	HSD 250/78
Colour Temperature	7800°K
Socket	GY9.5, single ended
Manufacturers Rated Lamp Life	3000 Hours replacement
Or	
GE	CSD250/2/SE
Colour Temperature	8500°K
Socket	GY9.5, single ended
Manufacturers Rated Lamp Life	3000 Hours replacement

COLOURS:

1 wheel with 12 dichroic colour filters plus white
With variable speed bi-directional rainbow effect
Step/linear colour changing is available

GOBOS:

1 Rotating gobo wheels:

7 interchangeable gobos+ white, glass or metal gobos can be fixed
Indexable, bi-directionally rotatable at variable speeds

1 Fixed gobo wheel :

10 interchangeable gobos+ white
bi-directional wheel scrolling at variable speeds
Gobo diameter: Φ 22.5mm
Gobo image diameter: Φ 17mm

PRISM/ FROST:

1x3 facet prism, bi-directionally rotatable at variable speeds

FOCUS:

DMX controlled focus

DIMMER:

0-100% linearly adjustable

SHUTTER:

Double shutter blades, 0.3~12 F.P.S

HEAD MOVEMENT:

Pan 540°, Tilt 270° with auto position correction

BEAM ANGLE:

17.5°

CONTROL:

DMX512, 3 pin, 5 pin interfaces

12 channels in short mode, 16 channels in standard mode, and 218 channels in extended mode.

Master/Slave mode

Stand-alone mode

Self-test mode

OTHER FUNCTIONS:

Adjustable Pan & Tilt speed

Fixture and lamp usage time display

LED display with English language menu

Energy saving function of the ballast

Built-in analyzer for easy fault finding, error messages

Built-in demo sequences

Input signal isolating protection

HOUSING:

Composite plastic, IP20

WEIGHT:

22Kg

SIZES:

See at below

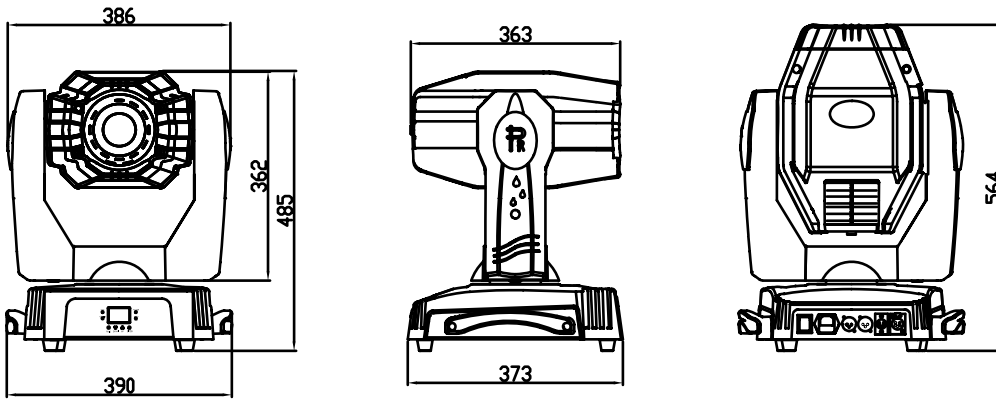

LIGHT OUTPUT:

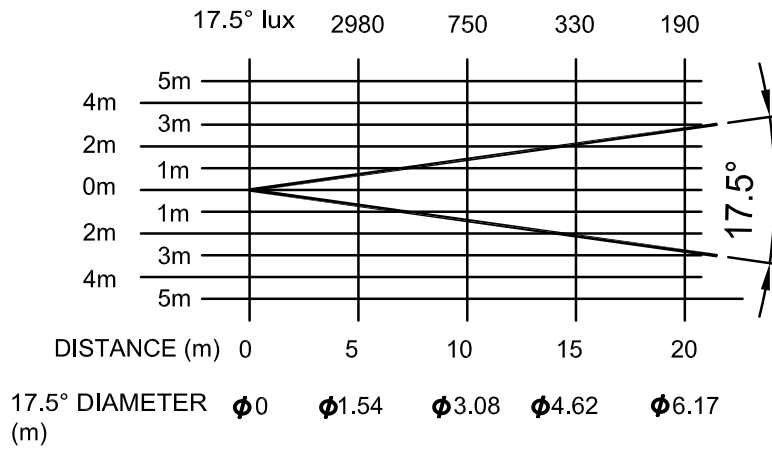

COMPONENT ORDER CODES

NAME	PART NO.	QUANTITY	REMARK
TRANSFORMER	040030039	1	21V 100W/230V 320W
THERMOSTAT	190010065	1	75°C
BALLAST	040070022	2	230V 50/60Hz
IGNITOR	040090016	1	230V 50/60Hz
LAMP	100050057	1	MSD250/2
TILT DRIVE BELT	290151252	1	HTD-612-3M
PAN DRIVE BELT	290151251	1	HTD-447-3M
FAN IN BASE	030060057	1	DC24V/2.88W
FAN NEAR THE LAMP	030060053	1	24V 1.4W
PAN MOTOR	030040053	1	57BYGH301-3A
TILT MOTOR	030040052	1	57BYGH101-2A
PRISM ROTATION MOTOR	030040095	1	17HD0013-36L
SHUTTER BLADE 1 MOTOR		1	
SHUTTER BLADE 2 MOTOR		1	
ROTATING GOBO WHEEL MOTOR	030040132	1	14HD0013-31L
PRISM/FROST MOTOR		1	
ROTATING GOBO WHEEL 2 MOTOR	030040148	1	17HD0013-62
FOCUS MOTOR	030040112	1	17HD0013-38L 5*15
FIXED GOBO WHEEL MOTOR		1	
COLOUR WHEEL MOTOR		1	
MOTOR DRIVE PCB	230020252	1	
DISPLAY PCB	230020249	1	

PR LIGHTING LTD.

1582 Xingye Avenue, Nancun Panyu
Guangzhou, 511442 China
TEL: +86-20-3995 2888
FAX: +86-20-3995 2330

P/N: 320020009
Last Revision: 20080828